

# DA

## TIME DELAY TIMERS

**Industrial Timer Company**

30 Industrial Park Road

Centerbrook, CT 06409

800-394-7130

[www.industrialtimercompany.com](http://www.industrialtimercompany.com)



### DESCRIPTION

The DA series timers are basic time delay units designed for surface mounting. The DA11 features a knob for setting the time delay, while the DA21 has a locking nut. A clutch motor is used as the timing element in all units, and automatic reset upon removal of power is standard. The load switch is an isolated single pole, double throw switch.

### APPLICATION

These basic timers are designed for applications where infrequent adjustment is required and no progress indication is necessary. Typical applications include: welding equipment, coffee machines, packaging equipment, and a wide variety of other industrial machinery.

### OPERATION

- 1) To set the duration of the time delay on the DA11, set the selector knob to the desired time. On the DA21, loosen the lock nut, turn the dial to the desired time and retighten the lock nut.
- 2) To start the time delay, close the customer supplied switch connecting power to the motor.
- 3) At the end of the delay period, the switch in the timer will change state.
- 4) To reset the timer, open the switch connecting power to the motor.
- 5) To start the time delay again, wait for the timer to reset and close the switch supplying power to the motor.

### SPECIFICATIONS

Repeat Accuracy	±0.75% of the total time range.
Reset Time	See table
Load Switch Contacts	Isolated SPDT switch rated 10 amps non-inductive
Wiring	Load switch, solder terminals Motor - DA11, 6-inch leads Motor - DA21, solder terminals
Voltage	120V/60Hz standard. Consult factory for other voltages and frequencies.
Agency Approval	UL, CSA

### STANDARD MODELS

Model Number	Time Cycle	Maximum Reset Time
DA11-031	14 sec.	1.0 sec.
DA11-032	57 sec.	1.5 sec.
DA11-033	4.5 min.	15 sec.
DA11-034	9.5 min.	120 sec.
DA11-035	114 sec.	9 sec.
DA11-036	5.7 sec.	.25 sec.
DA21-001	14 sec.	1.0 sec.
DA21-002	57 sec.	1.5 sec.
DA21-003	4.5 min.	15 sec.
DA21-004	9.5 min.	120 sec.
DA21-005	114 sec.	9 sec.

# DA

## TIME DELAY TIMERS

### DA11 DIMENSIONS

Industrial Timer Company

30 Industrial Park Road

Centerbrook, CT 06409

800-394-7130

[www.industrialtimercompany.com](http://www.industrialtimercompany.com)

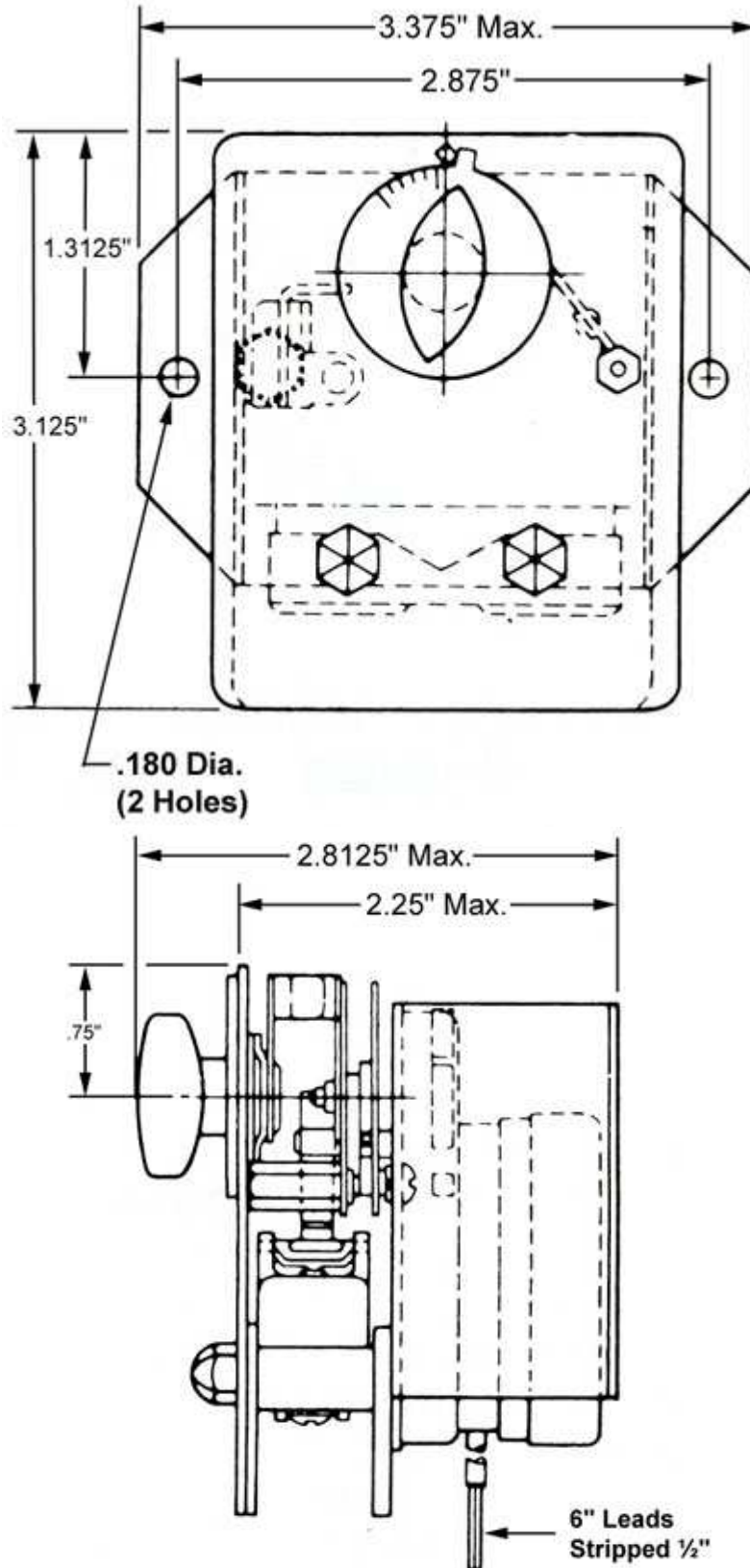

# DA

## TIME DELAY TIMERS

### DA21 DIMENSIONS

**Industrial Timer Company**

30 Industrial Park Road

Centerbrook, CT 06409

800-394-7130

[www.industrialtimercompany.com](http://www.industrialtimercompany.com)

